



Lane Line Trap

Art. No. 2010004

The storage solutions of your racing lane lines will make a difference for how long your lane lines will last. An important advantage using Lane Line Traps is that you can avoid storage trolleys on pool deck and thus have free space for other activities. The Lane Line Trap is an excellent solution for public pools as it is embedded on pool deck and will bring your lane lines into a basement storage. It fits all Malmsten racing lines. In the basement they can either hang freely, from a hook on a roll mechanism, or be stored in suitable storage bags. The trap comes with a protective roll mechanism that prevents damage to the lane lines. There is an anti-slip cover which has to be opened with a tool to avoid any tampering or accidents. One lane line is recommended per trap opening. The lane line trap is custom designed to fit your pool deck floor and we will need to have your specific measurements. A protective anti-slip cover plate is included. It may also be custom-made to accommodate the pool deck ceramic tiles. Earth-bonding is recommended. All of our goods for embedding in concrete are electropolished for extra protection against corrosion.

Advantages:

- Proven basement storage solution
- Made of stainless steel, high quality and long lasting
- Equipped with foldable protective roller

Product Information:

Material: Stainless steel 316L (EN1.4414)

Trap opening: Ø 350 mm

Measurements are required when ordering. See next page for sketch on measurements and installation info.

Associated Products:



1011001 Storage Bag
The Lane Line Trap can be combined with our storage bags. 4 different sizes available.

Selected When it Counts

The Lane Line Trap is manufactured from stainless steel EN 1.4404/316L.
It fits all Malmsten racing lines in dimension \varnothing 150 mm and \varnothing 100 mm.
Each Lane Line Trap is equipped with two anchors for affixing of racing lines.

During installation, the Lane Line Trap shall be fixed in correct position to the concrete slab.

Please make sure the water protective sealant covers the horizontal flange.

The cover plate is removed with help of the supplied tool.

The Lane Line Trap shall be earth-bonded.

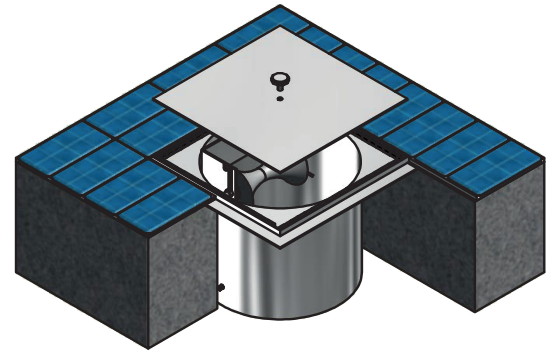

Measurements required when ordering:

H1= top edge ceramic layer to ceiling underneath (total required height for drilling).

H2= desired depth from finished floor to flange intended for connection of the floor sealing layer. Minimum size is 20 mm!

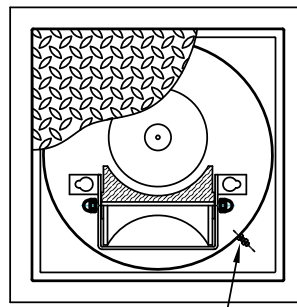
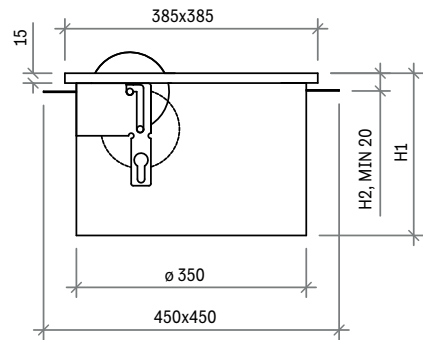

M6 Earthbound screw

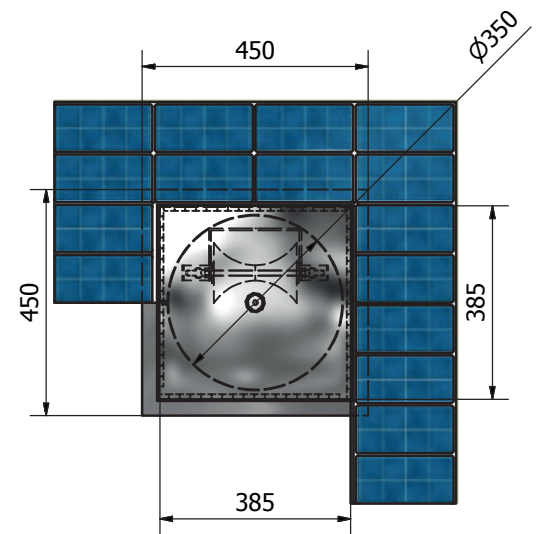

Dimensions for drilling holes through floors. Required when ordering:

Round opening: \varnothing 380 mm

Square opening: 370 x 370 mm

Follow installation instructions:

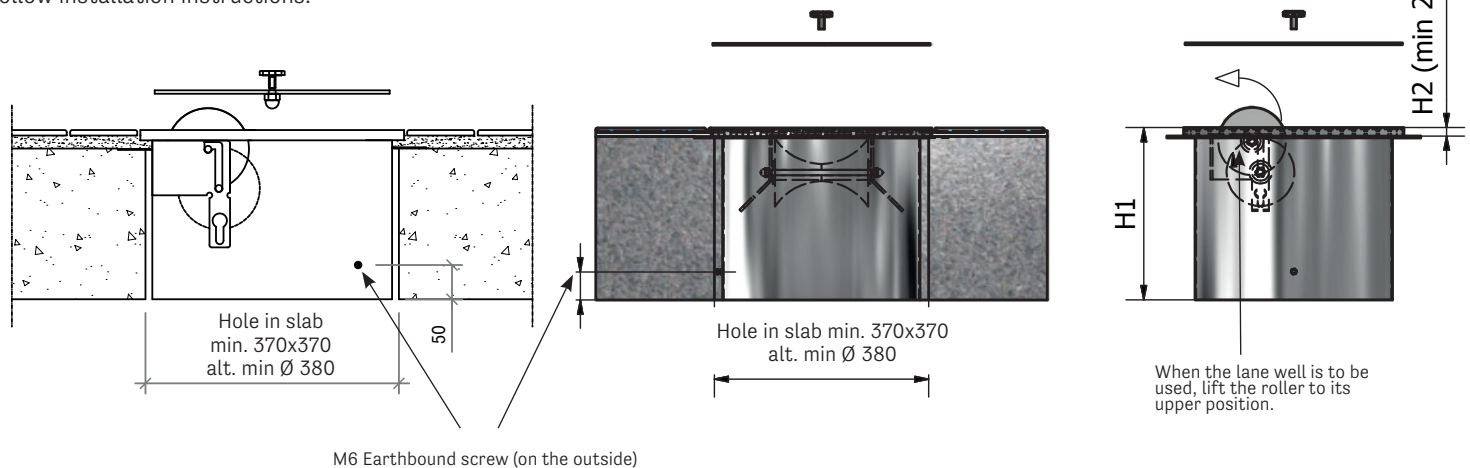

M6 Earthbound screw (on the outside)

USAGE INFORMATION:

Inspect functionality and installations once a year.

Open trap shall require clear warning signs and supervision to avoid any potential accidents.



Selected When it Counts

